

THE INFLUENCE OF THE ORGANIZATIONAL PROCESSES ON JOB SATISFACTION

Dragana Došenović

Assistant Professor; Faculty of Economics, University of Banja Luka, Banja Luka,
Bosnia and Herzegovina; dragana.dosenovic@ef.unibl.org

Marija Todorović

Diplomirani menadžer - kultura i mediji – master; Aska Media PR, Belgrade, Serbia;
askamediasocial@gmail.com

Abstract: *The concept of job satisfaction, which is most often defined as a satisfactory or positive emotional state that arises as a result of evaluating work or work experience, is one of the most important and most researched employee work-related issues. The relevance of the observed concept is the result of the belief that any changes in the level of job satisfaction have numerous positive, but also negative consequences, both for the individual and for the organization. In addition to the demographic or personal characteristics of employees, the cause of changes in the level of job satisfaction may be related to the organizational elements through which the work environment is shaped. As the demographic characteristics of employees cannot be greatly influenced, the attention of researchers is usually focused on a group of organizational factors or characteristics. Precisely for that reason, the research problem presented in this paper is the influence of the process in the organization on job satisfaction in various organizations operating in the Republic of Srpska. The main goal of this paper is to investigate and determine the existence and nature of the relationship between defined process factors in the organization as independent variables and their impact on job satisfaction as dependent variables. In order to investigate the observed impact and prove the set hypotheses, an empirical research was conducted, using a custom-made survey questionnaire, on a sample of 738 workers employed in 283 organizations from the Republic of Srpska. Reliability analysis, expressed by the Cronbach's alpha coefficient, shows a very high reliability of the developed instrument for testing satisfaction with organizational design. Testing of the set hypothesis was performed using correlation analysis, and the obtained results confirmed the hypothesis which claims that the processes in the organization affect job satisfaction.*

Keywords: *job satisfaction; processes; organizational design; human resource management.*

JEL classification: *J24, J28, L22, M21.*

INTRODUCTION

In modern business operations environment, with the increasing dynamism and complexity of the external and internal environment, organizations are forced to turn to creating added value through human capital. Thus, human resources have become a significant potential source of competitiveness and business success, and human resource management is becoming increasingly important in modern organizations. In addition to the employee competencies, job satisfaction plays a very important role. Job satisfaction is a satisfactory or positive emotional state that arises as a result of evaluating a job or work experience (Locke, 1969).

Organization and management of human resources theory deals with, among other things, the connection between the processes in the organization and job satisfaction. Thus, the processes in the organization have been identified as one of the causes of job satisfaction and *the research question* has been established: Do the processes in the organization, and in what way, affect job satisfaction?

Although at first glance it seems that the answer to this question is simple, there is no scientific knowledge, i.e., scientific confirmation of whether the processes in the organization have an impact on job satisfaction. Such research will be a pioneering attempt to understand the nature and intensity of the relations between the observed variables. For the above-mentioned reasons, *the subject of research* is within the business management scientific field and more specifically - organization and management scientific field. Empirical research was conducted in organizations operating in the Republic of Srpska.

The main goal of the research is to investigate and determine the existence and nature of the influence of organizational processes on job satisfaction. To this end, *scientific goals* have been set: to describe the impact of the organizational processes on job satisfaction; to classify process-related factors; to establish new scientific facts and insights into the impact of the processes in the organization on job satisfaction; to explain the cause-and-effect codependence and to provide information for the organization and personnel management. *Pragmatic goals* refer to the benefits that employees, managers and business owners will have. The work *hypothesis* is: Processes, as an element of organizational design, affect job satisfaction.

THEORETICAL ASPECTS OF RESEARCH

Job satisfaction

The concept of job satisfaction developed from organizational theory. This concept represents one of the most important and most researched attitudes that employees have regarding work (George & Jones, 2012; McPhail, Patiar, Herington, Creed, & Davidson, 2015). Due to the great interest many authors have in researching and studying the observed concept, it can be said that job satisfaction has become a central research problem (Goswami & Dsilva, 2019), one of the most frequently researched variables and one of the most popular research topics in management and psychology, that is in the field of organizational research related to organizational behavior and human resource management (Van Der Westhuizen, Pacheco, & Webber, 2012; Yahyagil, 2015; Shiu, Hassan, & Parry, 2015).

When it comes to the concept of job satisfaction in the scientific and professional literature, numerous definitions can be found, and some of them are:

- emotional response to different aspects of work (Kinicki & Fugate, 2016);
- the extent to which people love their job (Spector, 2017);
- attitudes and feelings that people have towards work (Armstrong, 2017);
- the degree to which the employee has a favorable or positive feeling about the job and work environment (Hoy & Miskel, 2013) and the like.

What is common to most of the above definitions is that most authors believe that job satisfaction essentially includes work-related feelings that are expressed through employee reactions to various aspects of work (Muterera, Hemsworth, Baregheh, & Garcia-Rivera, 2018). As most definitions contain the importance of feeling or affect and cognition or thinking (Lan, Okechuku, Zhang, & Cao, 2013), it can be said that the concept of job satisfaction contains an affective and cognitive dimension, in the sense that the observed concept develops through affective and cognitive reactions of employees related to their work (Locke, 1969; Organ & Near, 1985; Judge & Ilies, 2004; Rich, Lepine, & Crawford, 2010).

However, a review of the available literature in the observed field shows that in the existing literature, one definition has been singled out that is most often used and cited in various publications. It is a definition given by Edwin Locke back in 1969, according to which job satisfaction is a *satisfactory or positive emotional state that arises as a result of evaluating work or work experience* (Locke, 1969).

Existing theories describe job satisfaction as a complex phenomenon that is related to numerous factors, and whose mutual interaction plays a great role and significance for the survival, growth and development of any organization. Thus, all factors can generally be classified into: (1) causes and (2) effects of changes on the job satisfaction level, although it has been proven that there may be a two-way relationship between certain factors and job satisfaction. Job satisfaction can be viewed in two ways, as: (1) a dependent variable (Balci, 2011) and (2) an independent variable (Schermerhorn, Hunt, Osborn, & Uhl-Bien, 2012).

If job satisfaction is viewed as a dependent variable, the literature most often cites and uses a classification according to which all factors can be grouped into two basic categories, namely: (1) demographic or personal factors and (2) environmental factors or organizational factors (Crossman & Harris, 2006). In doing so demographic (Ashraf, 2020) or personal factors include personal attributes or characteristics of employees (gender, age, education, marital status, race, work experience, work experience in the organization, etc.), while environmental factors or organizational factors refer to factors related to the work itself or working environment.

The most significant outcomes of job satisfaction are most often mentioned: productivity or performance, organizational commitment, absence and intention to leave the job (Gómez-Mejía, Balkin, & Cardy, 2016).

Based on the performed analysis, it can be concluded that job satisfaction is a complex concept that is related to a large number of factors (Soomro & Shah, 2019). All factors related to the observed concept can be classified into two groups, where the factors that affect the level of job satisfaction are the causes or determinants of job satisfaction, while the factors that can be affected by job satisfaction are the outcomes, i.e., consequences or effects of job satisfaction. Thus, job satisfaction in relation to the factors from the first group is viewed as a dependent variable, while for factors from

the second group, job satisfaction is an independent variable. Based on a review of the literature (Huynh & Hua, 2020) and the aforementioned analysis, the association of factors with job satisfaction can be presented using Figure 1 which identifies the most important causes and effects of changes in job satisfaction levels.

Figure 1. Causes and effects of changes in the level of job satisfaction

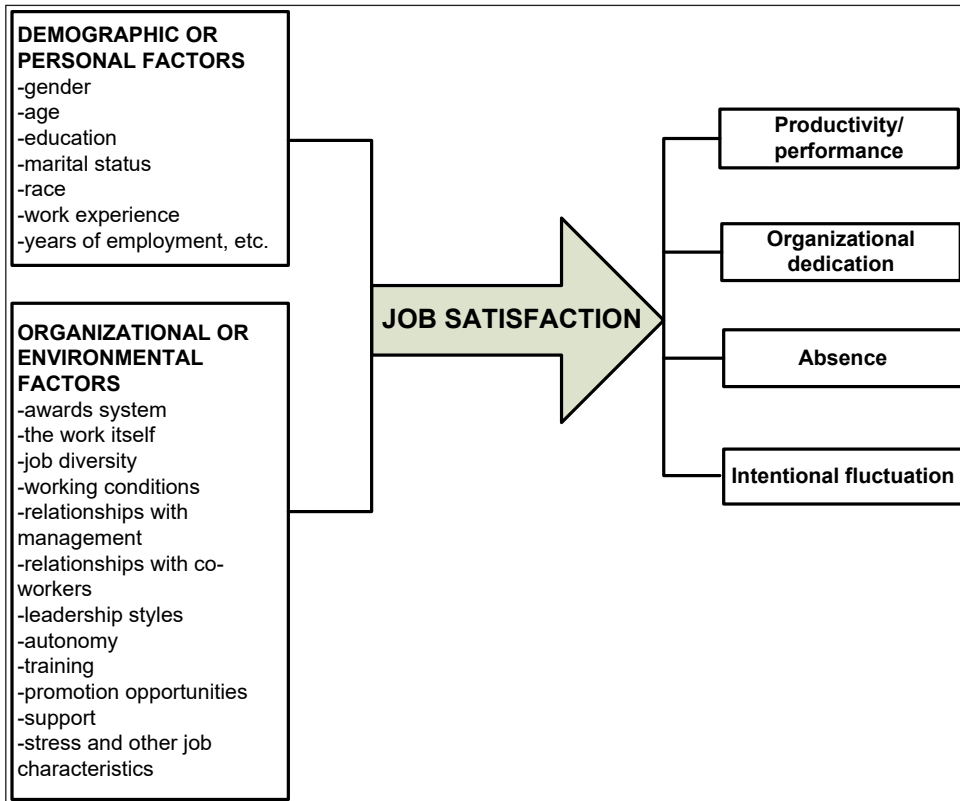

Source: Authors

Process organization of the company

Processes consist of interconnected activities through which the transformation of input quantities or inputs into final outcomes or outputs (Zaheer, Rehman, & Khan, 2010), or related activities that operate within the boundaries of the organization in order to enable organizational units to connect and act together. Thus, processes have a beginning and an end, clearly defined inputs and outputs, and human, information and other resources are necessary for their development. Processes refer to the way in which existing resources are used to achieve defined goals. Together with lateral connections, processes represent a means for coordination and integration of activities, i.e., a means by which the barriers set by the structure are overcome.

The business system has the function of a business process and the following set of working systems:

$$POS = f(IT, R, K, P, N, TR, M, TE, QS, D, U, S, RU, PK, F, OI)$$

Where the operating systems are:

- IT - research of market needs for the process results,
- R - development of a prototype of the future process result,
- K - construction of process results,
- P - production planning and preparation,
- N - procurement of raw materials and equipment for the development of process results,
- TR - external and internal transport of materials, equipment and process results,
- M - warehouse for materials, equipment and process results,
- TPP - technology of machining parts and assembly of process results,
- Q - management and quality assurance of process results,
- D - sales and distribution of parts and process results,
- U - installation or assembly of the product at the place of use,
- S - servicing or maintenance of the product at the customer or user,
- RU - management,
- P - legal and personnel affairs,
- F - finance and accounting,
- OI - asset security and electronic information processing.

Figure 2. Business system process functions

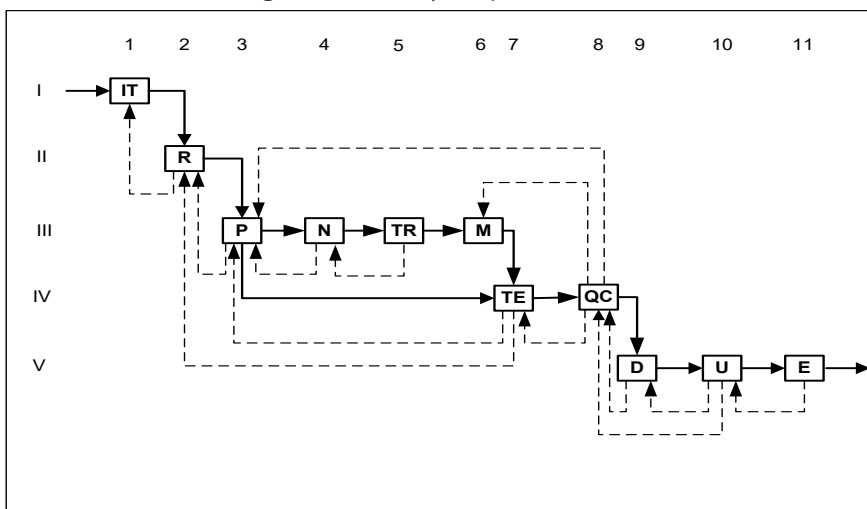

Source: (Todorović, Upravljanje kvalitetom, 2009)

The business system has the scheme shown in Figure 3. On the direct branch and in the working coupling of the business system, there are working systems IT, R, K, P, N, TR, M, D, U, S and TE.

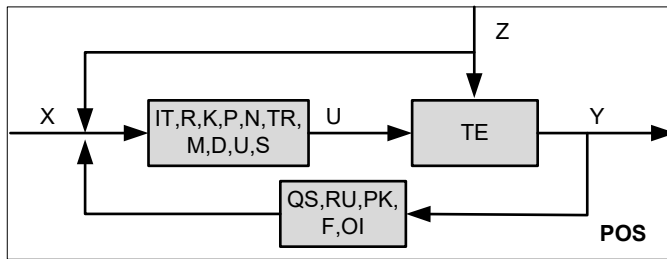
Figure 3. Business process scheme

Source: (Todorović, Upravljanje kvalitetom, 2009)

At the entrance X to the business system, there are: the required energy, raw materials, semi-finished products, production materials and documentation with business tasks. The business system is inevitably affected by disturbances of Z of different character: poor planning, delays in work, lack of financial resources, unfulfilled contracts, strikes, atmospheric disasters, etc. which adversely affect the system and interfere with its business. At the exit Y from the business system, there are: work spent and lost, jobs done and data on business realized.

In the feedback branch and coupling of the business system, there is the QS system as well as the RU, PK and F systems, as well as the OI. They receive the information Y with the data on the realized business at the output of the business system, compares it with the information X with the business tasks at the entrance, in order to perform the necessary management in the business according to the difference (X-Y).

In order for an organization to be efficient and effective, a “process approach” needs to be applied. Business process optimization (Todorović, Todorović, & Tomaš, Uloga interne revizije u borbi protiv kompjuterskog kriminala, 2020) is achieved by presenting processes transparently, aligning them with business strategy and specific operational requirements, and optimizing and computerizing in accordance with good process management practices, and then having them continuously monitored, adapted and improved.

When it comes to the impact of organizational processes and their dimensions on job satisfaction, a review of the literature identified five studies that, among other things, analyze the existence and nature of the relationship between process and job satisfaction (Carbonell & Rodriguez-Escudero, 2013; Tomažević, Seljak, & Aristovnik, 2014; Zhu, Xie, Warner, & Guo, 2015; Pacheco & Webber, 2016; Xia, Zhang, & Zhao, 2016). Based on the analysis of the aforementioned research, and which studies the impact of processes and their dimensions on job satisfaction, it can be concluded that previous research, which is not numerous, does not observe the overall impact of the process on job satisfaction. The analysis of previous studies shows that the subject of research was most often participatory decision-making, that is the involvement of employees in the decision-making process, so in previous research done, only individual processes, that is their individual dimensions, were analyzed.

RESEARCH METHODS

With the intention to best solve the research problem, the set research goals and the research hypothesis, we chose a quantitative research methodology.

A survey method was used to collect the data. The introductory part of the questionnaire lists the characteristics of the respondents and general information about the organization. The second part lists the process factors that affect job satisfaction, which are:

- Accuracy and understanding of the decision-making process,
- Opportunity to participate in the decision-making process that is important for the business,
- Opportunity to participate in the process of making important decisions at the level of the organization,
- Accuracy and comprehensibility of the communication process,
- Availability of information needed to do the job,
- Availability of other information,
- Quality of feedback,
- Resource availability,
- Quality of communication with the manager and
- Quality of communication with co-workers.

Factors were evaluated based on the Likert scale from 1 to 5 in two categories: importance and satisfaction. The assessment of importance goes from: 1. It doesn't matter to me at all, 2. It doesn't matter to me, 3. It is moderately important to me, 4. It is important to me and 5. It is very important to me. Satisfaction rating goes from: 1. I am not satisfied at all, 2. I am not satisfied, 3. I am moderately satisfied, 4. I am satisfied and 5. I am completely satisfied.

Data processing was performed on the basis of statistical software for social sciences - SPSS (Statistical Package for Social Sciences - SPSS).

Data analysis was performed on the basis of methods used in management and organization, which are: Cause and effect analysis, Similarity diagram, Interrelationship diagram and Field of influence analysis.

The target population includes a set of all organizations (economic entities) that are registered in the Chamber of Commerce of the Republic of Srpska, while the target respondents are workers who are employed in organizations. The choice of the Chamber of Commerce as a database for determining the target population is justified by the fact that it is an organization whose members are companies, banks, insurance companies and other financial organizations that perform business activities in the Republic of Srpska, as well as the fact that, based on the Republic of Srpska Register Rulebook (Official Gazette of RS, No. 121/08) and the Law on the Chamber of Commerce of Republic of Srpska (Official Gazette of RS, No. 65/08), the Chamber of Commerce is the only authorized institution in charge of establishing and maintaining the Republic of Srpska Business Register.

From the set of 3,824 total registered organizations (as of April 25, 2017), micro-organizations (organizations that employ up to 5 workers) are excluded, given the fact that there are not any clearly defined and built organizational systems, as well as sufficiently developed elements. processes in the organization. This leads to the target

population, which consists of a set of 1,073 organizations from the Republic of Srpska, where the target respondents are all workers who are employed in the given organizations.

The planned sample size was calculated using various formulas showing that for a final population consisting of 1,073 elements, with a most commonly used confidence level of 95% and a marginal error of 5%, a sample consisting of 283 elements¹ was sufficient.

In that way, a simple, random sample of 283 organizations was registered in the Business Register of Republic of Srpska, where the planned number of respondents is a set of all workers employed in the selected organizations, and whose total number is 6,983 workers. The selection of a random sample in the first stage (6,983 workers) enabled the implementation of empirical research, where in the second stage the response of all workers from the selected organizations was expected.

The procedure of collecting empirical data, which included sending the created questionnaire to all employees of the organizations selected in the sample and collecting answers from the respondents, lasted in the period from June to November 2018. After six months, a total of 794 respondents completed the questionnaire. However, all respondents who did not fill in the questionnaire properly, as well as those who did not answer all the questions, were eliminated from the sample. Thus, by eliminating the questionnaire with the missing data, 738 respondents participated in the conducted empirical research, which is the final sample of respondents. As of the planned 6,983, 738 respondents completed the questionnaire, the response rate in the survey was 10.57%, which is an acceptable response rate when it comes to organizational surveys (Baruch & Holtom, 2008). However, there was a non-random or non-sample (systemic) error due to the absence of answers from the respondents in the research. This error occurred because many respondents who were included in the study did not provide answers.

THE RESEARCH RESULTS

Table 1 shows the average rated level of importance of the identified process dimensions. The obtained results show that the respondents from the sample on average consider that all the stated dimensions of the process are important for their work (the assessed level of importance for each aspect has a value above the neutral environment, with nine out of ten aspects having average ratings between “important” and “very important”). This confirmed the results of the pilot study, so the inclusion of all identified dimensions in the proposed sub-scale for assessing satisfaction with the processes is further justified. Given that all identified process dimensions are rated as important on average, no correction is required. If the identified dimensions are ranked according to the assessed level of importance, it can be noticed that for the respondents from the sample, the most important is the availability of information needed to do the job (fifth dimension), where the respondents’ answers deviated the least from the

¹ Starting from the formula for marginal error: $z \cdot \sqrt{\frac{p(1-p)}{n}} \sqrt{\frac{N-n}{N-1}} = 0,05$ we get:

$$1,96 \cdot \sqrt{\frac{0,5 \cdot 0,5}{n}} \sqrt{\frac{1073-n}{1072}} = 0,05, \text{ where it follows: } n = 283.$$

arithmetic mean. On the other hand, the assessed level of importance is the lowest for the third dimension, which refers to the possibility of participating in the process of making important decisions at the organizational level, and where the average largest deviation of respondents' answers from the arithmetic mean.

Table 1. Descriptive measures of the process-related subscale (importance of dimensions)

Variable	Sample size	Arithmetic means	Standard deviation
Accuracy and understanding of the decision-making process,	738	4.05	.882
Opportunity to participate in the decision-making process that is important for the business,	738	4.36	.763
Opportunity to participate in the process of making important decisions at the level of the organization,	738	3.67	1.069
Accuracy and comprehensibility of the communication process,	738	4.14	.786
Availability of information needed to do the job,	738	4.50	.674
Availability of other information,	738	4.22	.765
Quality of feedback,	738	4.36	.732
Resource availability,	738	4.44	.710
Quality of communication with the manager and	738	4.47	.725
Quality of communication with co-workers.	738	4.34	.795

Source: Based on the exit from the SPSS

By including control variables in the analysis, it can be determined whether the average assessed level of importance of individual dimensions differs by groups of respondents formed on the basis of control variables.

To determine whether the calculated differences between groups of subjects were statistically significant, two tests were used, the Mann-Whitney Test and the Kruskal-Wallis Test. Due to the large number of control variables, only data on p values are shown in Table 2.

Table 2. Summary data on p values (testing the statistical significance of differences between groups of respondents) - subscale related to processes (importance of dimensions)

Variable	VP1	VP2	VP3	VP4	VP5	VP6	VP7	VP8	VP9	VP10
Gender*	.824	.793	.550	.534	.927	.296	.423	.838	.168	.552
Age**	.001	.151	.088	.285	.687	.282	.159	.302	.266	.049
Level of Education**	.000	.199	.000	.112	.053	.328	.288	.017	.359	.008
Position*	.000	.000	.000	.000	.000	.000	.000	.000	.000	.000
Work experience**	.002	.149	.090	.225	.105	.247	.159	.468	.505	.345
Work experience in the organization**	.109	.367	.026	.970	.470	.523	.979	.909	.424	.429
Size of the organization**	.392	.744	.565	.848	.552	.961	.088	.077	.474	.763
Ownership structure*	.681	.026	.788	.538	.417	.370	.129	.370	.777	.594
Activity*	.424	.718	.769	.183	.248	.968	.937	.487	.525	.291

* Mann-Whitney Test

** Kruskal-Wallis test

Ho: There are no statistically significant differences between groups of respondents.

H1: There are statistically significant differences between groups of respondents.

Source: Author's calculation

In order to determine which groups of subjects statistically significant differences in the estimated level of importance of individual dimensions of the process there are (in the case when the control variable forms three or more groups of subjects), an additional analysis was performed using the Mann-Whitney Test.

It can be concluded that there are statistically significant differences between certain groups of respondents in the assessed level of importance of certain dimensions of the process. Also, it can be noticed that the position of the respondents is the only control variable in which there are statistically significant differences in all observed dimensions of the process (p value is less than 0.05). On the other hand, statistically significant differences in the estimated level of importance of the observed dimensions of the process do not exist in groups of respondents formed on the basis of gender of respondents, size and activity of the organization. For other control variables, statistically significant differences between groups of respondents exist only for certain dimensions of the process, namely: age (two dimensions), level of education (two dimensions), work experience (one dimension) and work experience in the organization (one dimension).

The relationship between the individual dimensions of the process can be analyzed on the basis of the average assessed degree of satisfaction with each of the dimensions, and descriptive measures (arithmetic mean and standard deviation) are presented in Table 3.

Table 3. Descriptive measures of the subscale related to processes (dimensional satisfaction)

Variable	Sample size	Arithmetic means	Standard deviation
Accuracy and understanding of the decision-making process,	738	3.51	1.068
Opportunity to participate in the decision-making process that is important for the business,	738	3.41	1.128
Opportunity to participate in the process of making important decisions at the level of the organization,	738	3.34	1.092
Accuracy and comprehensibility of the communication process,	738	3.55	1.062
Availability of information needed to do the job,	738	3.59	1.059
Availability of other information,	738	3.51	1.085
Quality of feedback,	738	3.53	1.076
Resource availability,	738	3.54	1.086
Quality of communication with the manager and	738	3.57	1.091
Quality of communication with co-workers.	738	3.97	.935

Source: Based on the exit from the SPSS

The previous table shows the average rated level of satisfaction with the identified process dimensions. Based on the collected data, it can be seen that the respondents are on average satisfied with the existing processes in the organization, given that the average estimated value of respondent satisfaction with each of the aspects is above a neutral median. If the identified dimensions of the process are ranked according to the assessed level of satisfaction, the previous table shows that the average level of satisfaction of respondents is highest in the tenth dimension (quality of communication with associates), while the average level of satisfaction is lowest for the third dimension (opportunity to participate in the process of making important decisions at the level of the organization). The largest average deviations of respondents' answers from the arithmetic mean are present in the second dimension (possibility to participate in the decision-making process that is important for the job), while the smallest deviations occur in the tenth dimension (quality of communication with associates).

To determine whether the calculated differences in the estimated level of satisfaction with individual items were statistically significant, the Mann-Whitney Test and the Kruskal-Wallis Test were used. Due to the large number of control variables, only data on p values are shown in Table 4.

Table 4. Summary data on p values (testing the statistical significance of differences between groups of respondents) - subscale related to processes (dimensional satisfaction)

Variable	VP1	VP2	VP3	VP4	VP5	VP6	VP7	VP8	VP9	VP10
Gender*	.661	.476	.444	.788	.378	.377	.090	.007	.074	.216
Age**	.209	.637	.301	.354	.444	.047	.225	.418	.348	.008
Level of Education**	.000	.000	.000	.000	.000	.000	.000	.000	.000	.001
Position*	.000	.000	.000	.000	.000	.000	.000	.000	.000	.000
Work experience**	.139	.603	.327	.564	.764	.766	.712	.925	.653	.189
Work experience in the organization**	.489	.632	.582	.615	.215	.633	.863	.435	.284	.324
Size of the organization**	.005	.009	.204	.004	.003	.008	.011	.005	.008	.038
Ownership structure*	.003	.004	.071	.000	.001	.002	.008	.038	.001	.149
Activity*	.182	.220	.462	.310	.378	.124	.457	.128	.793	.693

* Mann-Whitney Test

** Kruskal-Wallis test

Ho: There are no statistically significant differences between groups of respondents.

H1: There are statistically significant differences between groups of respondents.

Source: Author's calculation

To determine between which groups of subjects there are statistically significant differences in the estimated level of satisfaction with individual dimensions of the process (in the case when the control variable forms three or more groups of subjects), an additional analysis was performed using the Mann-Whitney Test.

It can be concluded that there are statistically significant differences between certain groups of respondents in the assessed level of satisfaction with certain dimensions of the process. In the two control variables (level of education and position of the respondents) there are statistically significant differences in all observed dimensions of the process (p value is less than 0.05). Also, statistically significant differences in the assessed level of satisfaction for most of the observed dimensions of the process exist among respondents who come from organizations of different sizes (nine dimensions), as well as among respondents employed in organizations that differ in ownership structure (eight dimensions). However, there are control variables in which there are no statistically significant differences in the estimated level of satisfaction with the observed dimensions of the process (work experience, work experience in the organization and the organization), as well as control variables in which statistically significant differences in the estimated level of satisfaction exist in only one process dimensions (gender and age of respondents).

Correlation analysis was applied to test the hypothesis, and the results of the analysis are shown in Table 5.

Table 5. Testing of the hypothesis (Spearman's correlation coefficient)

		ZP	UZP
Spearman's coefficient	ZP		
	Correlation coefficient	1.000	.883**
	p - value (two-way test)	.	.000
	Sample size	738	738
	UZP		
	Correlation coefficient	.883**	1.000
	p - value (two-way test)	.000	.
	Sample size	738	738

** Correlation is significant at level 0.01 (two-way test)

Ho: In the set, there is no correlation between the observed variables.

X1: In the set there is a correlation between the observed variables.

Source: Based on the exit from the SPSS

Based on the calculated value of the correlation coefficient in the sample ($r_s = 0.883$) and the calculated p value ($p = 0.000$), several conclusions can be drawn:

- The correlation coefficient is positive (there is a direct monotonic relationship in the sample),
- There is a strong correlation in the sample,
- For any level of significance, it can be concluded that there is a quantitative correlation of the observed variables, i.e., that the observed relationship is statistically significant.

The previous table proves the existence of a statistically significant relationship between process satisfaction (calculated based on satisfaction with identified process dimensions) and overall job satisfaction. As the calculated correlation is strong, and the degree of correlation is positive, it can be stated that the respondents with a higher degree of satisfaction with the processes have a higher degree of overall job satisfaction, and vice versa.

As it has been proven that there is a strong correlation in the sample between process satisfaction and overall job satisfaction, and as the analysis showed that processes, together with their dimensions, were assessed as “important” for respondents’ work, it can be concluded that processes are an important satisfaction factor. business.

DISCUSSION

Regarding similar research conducted in countries in the region, a literature review found only one study (Tomažević, Seljak, & Aristovnik, 2014) that focused on analyzing the impact of individual elements of organizational design on job satisfaction. Table 6 presents the theoretical, methodological and conceptual aspects of the analyzed research.

In this research, the influence of two elements of organizational design (strategy and processes) on job satisfaction was analyzed. Processes were analyzed through satisfaction with the characteristics of organizational processes, quantitative methodologies were used, and primary and secondary data were collected using a questionnaire. The research was conducted on large samples, where the respondents were residents of one country from the region.

Table 6. Theoretical, methodological and conceptual aspect of research from the region in which the impact of the process in the organization on job satisfaction is studied

SN	Authors	Independent variables	Dependent variables	Control variables	Methodology	Respondents	Data source	Number of org.	Number of respondents	Country	Result
1.	Tomažević et al., 2014	Joint Assessment Framework (EU): leadership, strategy and planning, people, partnership and resources, processes	Job satisfaction	age, gender, level of education	quantitative, survey	workers employed in a law enforcement institution	secondary	1	1848	Slovenia	+

Source: Author (based on the sources listed in the table)

The results of this research show that process satisfaction is correlated with total satisfaction (correlation coefficient has a value of 0.513). To assess the elements of the organizational process and job satisfaction, Likert's glass with five degrees was used, as in our research. The results show that the respondents are dissatisfied with the existing processes (the average rated satisfaction is 2.77).

CONCLUSION

Identified process dimensions are important for the respondents' jobs - respondents included in the sample on average believe that all identified process dimensions are important for their work, with respondents having the most important information available to do the job, while the assessed level of importance is the lowest for a dimension related to the possibility of participating in the process of making important decisions at the level of the organization. Statistically significant differences in the average estimated degree of importance of certain dimensions of the process exist in groups of respondents formed on the basis of: age, level of education, position, work experience, work experience in the organization and ownership structure of the organization. Respondents included in the sample are on average satisfied with the existing processes in the organization, where the average rated level of satisfaction of respondents is the highest in the dimension related to the quality of communication with associates, and the lowest for the dimension related to the ability to participate in important decision-making. Statistically significant differences in the average estimated degree of satisfaction with certain dimensions of the process exist in groups of respondents formed on the basis of: gender, age, level of education, position, size and ownership

structure of the organization. The correlation between process satisfaction and overall job satisfaction is statistically significant, the calculated correlation is strong, and the degree of correlation is positive ($r_s = 0,883$, $p = 0.000$), which shows that respondents with a higher degree of process satisfaction have a higher degree of overall job satisfaction. Processes are an important factor of job satisfaction - as it has been proven that there is a strong correlation between process satisfaction and overall job satisfaction, and how processes, together with their dimensions, are rated as “important” for respondents’ work, it can be concluded that the hypothesis claiming that *processes, as an element of organizational design, affect job satisfaction* has also been confirmed. The conducted research has numerous consequences both on theory and practice, and the basic implications of the work can be seen through the scientific and pragmatic contribution achieved by conducting theoretical and empirical research. The scientific contribution was achieved through the definition of a conceptual research model which enables a comprehensive study of the impact of processes in the organization on job satisfaction, given that the chosen model includes various elements of the process in the analysis. Managers of various organizations received specific recommendations and data on the assessed degree of importance and degree of satisfaction with certain characteristics of the process in the organization. Also, managers were given a tool which they can use to measure and evaluate the importance of various characteristics and process factors in the organization for employees, as well as employee satisfaction with these characteristics and factors. In this way, the negative effects that occur as a result of employee dissatisfaction with certain organizational characteristics of the process can be reduced and all the positive consequences that provide an increase in job satisfaction can be used.

LITERATURE

- Armstrong, M. (2017). *Armstrong’s Handbook of Human Resource Management Practice*. London: Kogan Page.
- Ashraf, M. A. (2020). Demographic factors, compensation, job satisfaction and organizational commitment in private university: an analysis using SEM. *Journal of Global Responsibility, 11*(4), 407-436.
- Balci, F. (2011). The effects of education on police officer job satisfaction: The case of Turkish national police. *International Journal of Human Sciences, 8*(2), 265–285.
- Baruch, Y., & Holtom, B. C. (2008). Survey response rate levels and trends in organizational research. *Human Relations, 61*(8), 1139-1160.
- Carbonell, P., & Rodriguez-Escudero, A. I. (2013). Management control, role expectations and job satisfaction of new product development teams: The moderating effect of participative decision-making. *Industrial Marketing Management, 42*(2), 248–259.
- Crossman, A., & Harris, P. (2006). Job Satisfaction of Secondary School Teachers. *Educational Management Administration and Leadership, 34*(1), 29-46.
- George, J. M., & Jones, G. R. (2012). *Understanding and managing organizational behavior*. Upper Saddle River: Prentice Hall.
- Gómez-Mejía, L. R., Balkin, D. B., & Cardy, R. L. (2016). *Managing human resources*. Boston: Pearson Education.
- Goswami, I., & Dsilva, N. R. (2019). Impact of job satisfaction and job stress on employees’ life in Mumbai’s hospitality sector. *Journal of Strategy and Management, 12*(3), 330-346.

- Hoy, W. K., & Miskel, C. G. (2013). *Educational Administration: Theory, Research, and Practice*. New York: McGraw-Hill.
- Huynh, T. N., & Hua, N. T. (2020). The relationship between task-oriented leadership style, psychological capital, job satisfaction and organizational commitment: evidence from Vietnamese small and medium-sized enterprises. *Journal of Advances in Management Research*, 17(4), 583-604.
- Judge, T. A., & Ilies, R. (2004). Affect and job satisfaction: A study of their relationship at work and at home. *Journal of Applied Psychology*, 89(4), 661-673.
- Kinicki, A., & Fugate, M. (2016). *Organizational Behavior: A Practical, Problem-Solving Approach*. New York: McGraw Hill.
- Lan, G., Okechuku, C., Zhang, H., & Cao, J. (2013). Impact of job satisfaction and personal values on the work orientation of Chinese accounting practitioners. *Journal of Business Ethics*, 112(4), 627-640.
- Locke, E. A. (1969). What is Job Satisfaction? *Organizational Behavior and Human Performance*, 4(4).
- McPhail, R., Patiar, A., Herington, C., Creed, P., & Davidson, M. (2015). Development and initial validation of a hospitality employees' job satisfaction index: Evidence from Australia. *International Journal of Contemporary Hospitality Management*, 27(8), 1814-1838.
- Muterera, J., Hemsworth, D., Baregheh, A., & Garcia-Rivera, B. R. (2018). The Leader-Follower Dyad: The Link Between Leader and Follower Perceptions of Transformational Leadership and Its Impact on Job Satisfaction and Organizational Performance. *International Public Management Journal*, 21(1), 131-162.
- Organ, D. W., & Near, J. P. (1985). Cognitive vs affect measures of job satisfaction. *International Journal of Psychology*, 20(2), 241-254.
- Pacheco, G., & Webber, D. J. (2016). Job satisfaction: how crucial is participative decision making? *Personnel Review*, 45(1), 183-200.
- Rich, B. L., Lepine, J. A., & Crawford, E. R. (2010). Job Engagement: Antecedents and Effects on Job Performance. *Academy of Management Journal*, 53(3), 617-635.
- Schermerhorn, J. R., Hunt, J. G., Osborn, R. N., & Uhl-Bien, M. (2012). *Organizational Behavior*. Hoboken: John Wiley & Sons.
- Shiu, E., Hassan, L. M., & Parry, S. (2015). The Moderating Effects of National Age Stereotyping on the Relationships between Job Satisfaction and its Determinants: A Study of Older Workers across 26 Countries. *British Journal of Management*, 26(2), 255-272.
- Soomro, B. A., & Shah, N. (2019). Determining the impact of entrepreneurial orientation and organizational culture on job satisfaction, organizational commitment, and employee's performance. *South Asian Journal of Business Studies*, 8(3), 266-282.
- Spector, P. E. (2017). *Industrial and Organizational Psychology: Research and Practice*. New York: John Wiley & Sons.
- Todorović, Z. (2009). *Upravljanje kvalitetom*. Banja Luka: Ekonomski fakultet.
- Todorović, Z., Todorović, B., & Tomaš, D. (2020). Uloga interne revizije u borbi protiv kompjuterskog kriminala. *Časopis za ekonomiju i tržišne komunikacije*, 10(2), 514-530.
- Tomažević, N., Seljak, J., & Aristovnik, A. (2014). The impact of CAF enablers on job satisfaction: the case of the Slovenian Law Enforcement Agency. *Total Quality Management & Business Excellence*, 25(12), 1336-1351.
- Van Der Westhuizen, D. W., Pacheco, G., & Webber, D. J. (2012). Culture, participative decision making and job satisfaction. *International Journal of Human Resource Management*,

23(13), 2661–2679.

- Xia, Y., Zhang, L., & Zhao, N. (2016). Impact of Participation in Decision Making on Job Satisfaction: An Organizational Communication Perspective. *Spanish Journal of Psychology*, 19(58), 1-14.
- Yahyagil, M. Y. (2015). Values, feelings, job satisfaction and well-being: the Turkish case. *Management Decision*, 2268-2286.
- Zaheer, A., Rehman, K. U., & Khan, M. A. (2010). Development and Testing of a Business Process Orientation Model to Improve Employee and Organizational Performance. *African Journal of Business Management*, 4(2), 149-161.
- Zhu, Y., Xie, Y., Warner, M., & Guo, Y. (2015). Employee participation and the influence on job satisfaction of the 'new generation' of Chinese employees. *International Journal of Human Resource Management*, 26(19), 2395-2411.

